



## V-Force 5000 Series

**GFV-5025, 5050**

Conventional Fire Alarm Voice Panel  
25 or 50 Watt Systems  
1-8 Zones

**GFV-5100**

Conventional Fire Alarm Voice Panel  
100 Watt Systems  
1-16 Zones

Phone: 888- 673-2900 • Local: 309-755-6352 • Fax: 309-755-8310 • email: inquire@globalfirecontrol.com

### DESCRIPTION

The V-Force 5000 Series Fire Alarm Voice Panels are high quality conventional voice systems designed to stand-alone or be accompanied with a Fire Alarm Control Panel.

The GFV-5025 / GFV-5050 / GFV-5100 panels provide 25W, 50W, and 100W of speaker power respectively. The GFV-5025 and GFV-5050 provides up to 8 speaker zones, while the GFV-5100 provides up to 16 speaker zones. They can be configured for general alarm or alarm by zone operation as required.

They include all necessary features to provide an effective voice evacuation system. With the addition of zone splitters, remote microphone cabinets, and expander modules allows them to be custom configured to satisfy the needs of most applications.

The Digital message repeater, microphone, 120 VAC power supply, and battery charger are all built in. The selection of tone and automatic message repeats, as well as the 6 hour delay of the AC power failure reporting feature are all field configurable.

V-Force 5000 series voice evacuation panels can be configured for Churches, Restaurants, Movie Theaters, Auditoriums, and High Rise buildings.



**GFV-5025/5050/5100 Series  
Shown with the door removed**

### FEATURES

- UL Listed
- 5 year warranty
- Power limited
- Dead-front construction
- Digitally recorded automatic evacuation message (Up to 4 minutes of message)
- 25/50/100 watt bullet-proof amplifier
- 120vac power supply and battery charger
- 25 or 70 VRMS field selectable
- Live microphone override of message and tone
- Analog addressable compatible
- High reliability, no maintenance, fully supervised.
- Easy installation and operation
- Natural sound recordings
- Built-in alarm and alert signals
- Up to 4 minute message capacity
- Works with 12VDC or 24VDC Fire Alarm Control Panels
- Works with Analog/Addressable and microprocessor based fire alarm control panels
- 3 minute message restart on microphone key
- 24 hour backup with four 12V7.2AH batteries
- Made in the USA by Evax

#### Typical Installation:

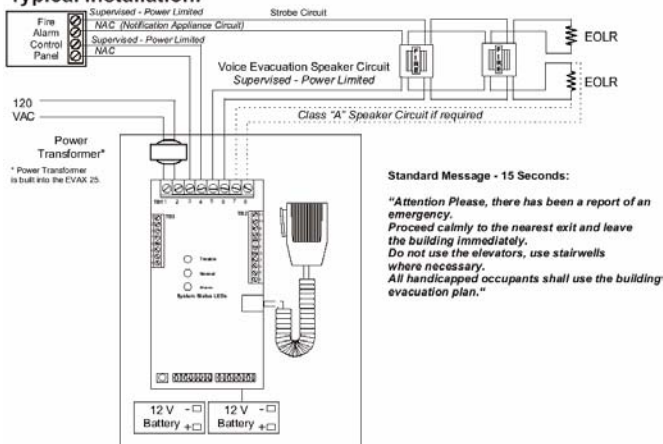



## V-Force 5000 Series

## Fire Alarm Voice Panel

### ORDERING INFORMATION (GFV-5025 & 5050)

<u>Model No.</u>	<u>Description</u>
GFV-5025	25W Voice Evacuation System with 1 speaker circuit, power supply/charger, paging microphone, and message repeater
GFV-5025-4	25W Voice Evacuation System with 4 speaker circuits
GFV-5025-8	25W Voice Evacuation System with 8 speaker circuits
GFV-5050	50W Voice Evacuation System with 1 speaker circuits, power supply/charger, paging microphone, and message repeater
GFV-5050-4	50W Voice Evacuation System with 4 speaker circuits
GFV-5050-8	50W Voice Evacuation System with 8 speaker circuits

### ORDERING INFORMATION (GFV-5100)

<u>Model No.</u>	<u>Description</u>
GFV-5100	100W Voice Evacuation System with 1 speaker circuit, power supply/charger, paging microphone, digital message repeater
GFV-5100-4	100W Voice Evacuation System with 4 speaker circuits
GFV-5100-8	100W Voice Evacuation System with 8 speaker circuits
GFV-5100-12	100W Voice Evacuation System with 12 speaker circuits
GFV-5100-16	100W Voice Evacuation System with 16 speaker circuits

### SPECIFICATIONS:

<b>Primary AC:</b>	
<b>GFV-5025</b>	120VAC @ 0.8A 60 Hz
<b>GFV-5050</b>	120VAC @ 0.6A 60 Hz
<b>GFV-5100</b>	120VAC @ 2.0A 60Hz

<b>Standby current:</b>	
<b>GFV-5025</b>	180mA @ 24VDC
<b>GFV-5050</b>	130mA @ 24VDC
<b>GFV-5100</b>	180mA @ 24VDC

**Back box dim.:** 14.5" W x 27" H x 4" D

### SPECIFICATIONS:

<b>Output:</b>	
<b>GFV-5025</b>	25 Watts @ 25/70 VRMS
<b>GFV-5050</b>	50 Watts @ 25/70 VRMS
<b>GFV-5100</b>	100 Watts @ 25/70 VRMS Tone and Voice

<b>Alarm current:</b>	
<b>GFV-5025</b>	1.0A @ 24VDC
<b>GFV-5050</b>	1.0A @ 24VDC
<b>GFV-5100</b>	2.5A @ 24VDC

**Back box color:** Red (standard), Charcoal Grey (opt.)



### Global Fire Control, Inc.

1201 7<sup>th</sup> Street, Suite 103  
East Moline, IL 61244

Phone: 888-673-2900

Local: 309-755-6352

Fax: 309-755-8310

email: [inquire@globalfirecontrol.com](mailto:inquire@globalfirecontrol.com)

*NOTICE: The information contained in this document is intended only as a summary and is subject to change without notice. The devices described in this document have specific instruction sheets, which cover various technical limitation and liability information. Copies of these instruction sheets and the General Product Warning and Limitations Document, which also contains important information are provided with the product and are available from Global Fire Control, Inc. Information contained in these documents should be consulted before specifying or using the product. For further information or assistance concerning particular problems contact Global Fire Control, Inc. Global Fire Control, Inc. reserves the right to change specifications without notice.*