



Sealed Lead-Acid Batteries

SLA1075

Capacity Specifications

Cut-off Voltage	20 Hr Rate (0.36 A)	7.2 Ah
1.75 v/c @ 25°C	10 Hr Rate (0.65 A)	6.5 Ah
1.70 v/c	5 Hr Rate (1.14 A)	5.7 Ah
1.55 v/c	1 Hr Rate (4.1 A)	4.1 Ah
	Bloc	Per Cell
Charge Voltage (constant)	Float	13.5~13.8
	Cycle	14.4~14.7
Discharge Current Amps (5 seconds maximum)	80	
Discharge Current Amps (maximum continuous)	50	
Max. Charge Current	2.16 A	
Approx Final Charge Current (2.25 v/c Float)	0.014 (14 mA)	
Approx Final Charge Current (2.45 v/c Cycle)	0.07 (70 mA)	
Terminal Type	Type A / (G optional)	
Self Discharge	9 months @ 21°C	
Case Material	ABS – Gray* or Black	

Due to changes in the manufacturing processes, specifications may change without notice.
*Gray option is Flame Retardant ABS.

Technical Specifications

Nominal Voltage	12V
Nominal Capacity	7.2 Ah (20 Hr Rate)
Dimensions	Length: 150 mm
	Width: 64.5 mm
	Height: 95 mm
Total Height/Terminal:	101 mm
Weight	Approx 2.75 Kg

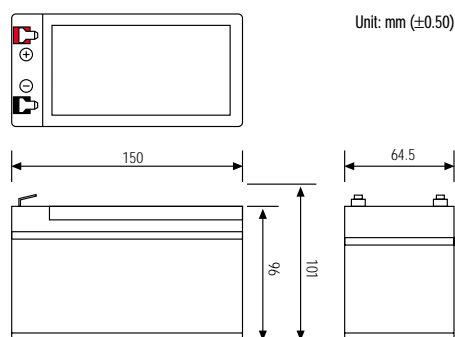

Actual Wattage / Ampere Capacity at Various Discharge Times (Volt per Cell @ 25°C)							
Cut Off Voltage	Time	5 Min.	10 min.	15 min.	30 min.	45 min.	60 min.
		1.75 v/c	W	45.4	30.77	23.28	12.9
25°C	A	25.94	17.58	13.3	7.37	5.89	4.61
1.67 v/c	W	47.76	31.4	23.9	13.09	10.04	8.07
25°C	A	28.6	18.8	14.31	7.84	6.01	4.83
1.60 v/c	W	49.28	31.52	24.0	13.3	9.3	7.79
25°C	A	30.8	19.7	15.0	8.31	5.81	4.87