



Phone: 888- 673-2900 • Local: 309-755-6352 • Fax: 309-755-8310 • email: inquire@globalfirecontrol.com

DESCRIPTION

Global Fire Control's manual pull station cover is a rugged poly-carbonate cover used to help protect manual pull stations and other devices from false alarms, vandalism, dust and weather. It comes in a variety of figurations to satisfy most applications.

It meets the requirements of the Americans with Disabilities Act (ADA). Specifically, it has been tested by Underwriter's Laboratories, for compliance with the 5lb. pull force requirement. In addition, the total depth of the unit when mounted is less than the required 4 inches.

What's more, the unit can be operated easily with one hand without having to grasp and when opened will not obstruct the use of the pull station, an important requirement for ADA applications.

Units with the optional alarm module can be used as false alarm deterrents in applications such as: schools, libraries, etc. When installed, the alarm module will emit a piercing scream when the cover is opened. This startling noise will help to deter most malicious pranksters and to indicate the location of the problem. This option comes with a 9 Volt battery and has a supervision circuit to provide a low battery chirp when the battery needs to be replaced.

The standard unit is flush mounting, yet it is very easily adapted to surface mounting with the addition of the extender kit.

A weatherproof kit is available which will allow the unit to be installed in outdoor applications. This optional kit will provide NEMA 3R protection to the device.

For applications where the manual pull stations are mounted on a surface that is rough, simply add the back-plate for easy mounting.



Model ST-FRC01 w/ST-XTR01

FEATURES

- UL/ULC Listed
- ADA Approved
- UV Stabilizer
- Low battery warning
- Alarm mode with piercing siren, 109dB at 10ft., comes with a 9Volt battery (This is an optional module)
- Extender kit for surface mount applications (This is an optional module)
- Weatherproof kit with gaskets, NEMA 3R rated (This is an optional module)
- Back-plate for mounting on rough surfaces (This is an optional module)
- Manufactured by SigCom



ORDERING INFORMATION

| <u>Model No.</u> | <u>Description</u> |
|------------------|---------------------------------------|
| ST-FRC01 | Front Cover Assembly |
| ST-ALM01 | Alarm Audible Module (Optional) |
| ST-WPK01 | Weatherproof Kit (optional) |
| ST-BKP01 | Back-plate Kit (optional) |
| ST-XTR01 | Extender for surface mount (optional) |

Component Detail

| Item# | Description | Part# |
|-------|-------------------|----------|
| 1 | Backplate Kit | ST-BKP01 |
| 2 | Extender Kit | ST-XTR01 |
| 3 | Weather Proof Kit | ST-WPK01 |
| 4 | Front Cover Kit | ST-FRC01 |
| 5 | Alarm Module Kit | ST-ALM01 |

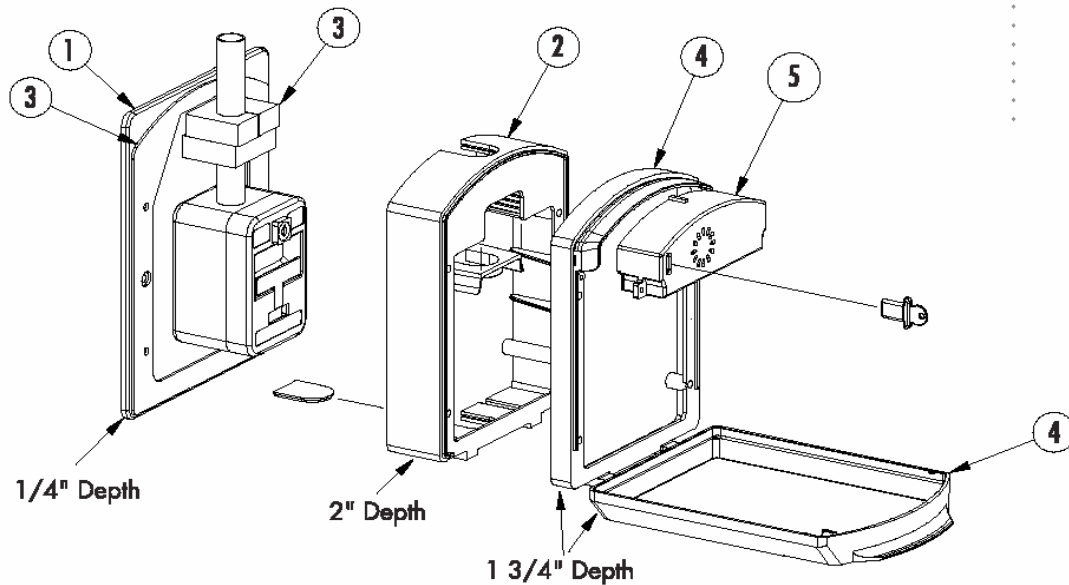

Global Fire Control, Inc.
1201 7th Street, Suite 103
East Moline, IL 61244

Phone: 888-673-2900
Local: 309-755-6352
Fax: 309-755-8310
email: inquire@globalfirecontrol.com