

# FIRERAY

## 50/100RU

### Technical Bulletin

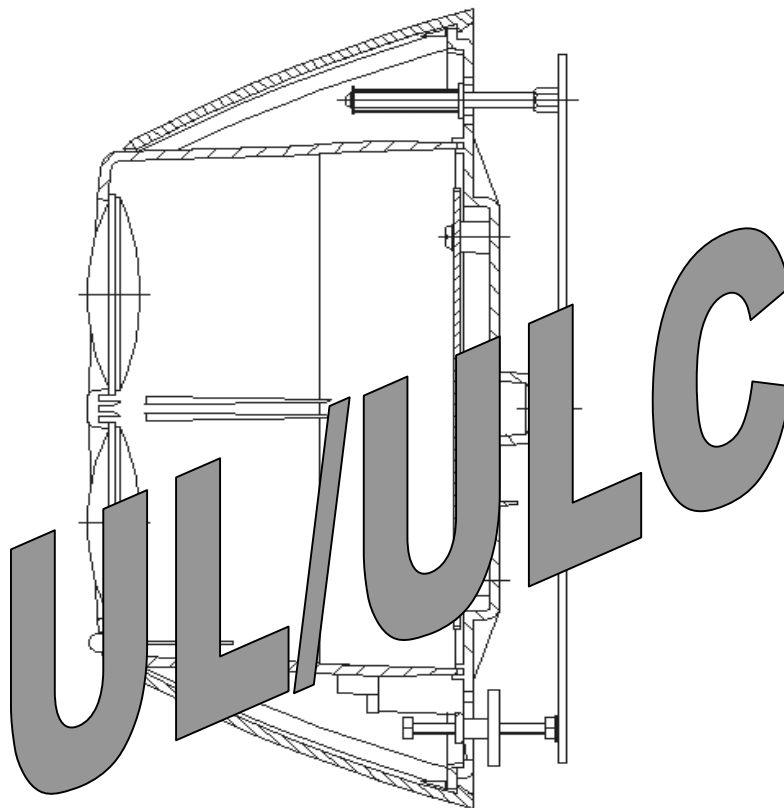

#### FEATURES

- Microprocessor controlled
- 50RU Range 15 – 160 Feet
- 100RU Range 160 – 330 Feet
- Unique simple alignment
- 12VDC or 24VDC operating voltage
- Selectable Alarm thresholds
- Low current consumption
- Automatic reset
- Automatic contamination compensation
- Low Level Controller Interface option



Fire Fighting Enterprises Ltd

## 1. System Description.

Fireray 50/100RU Detector comprises a Transmitter and Receiver contained within one enclosure.

The Detector installs to the building fabric between 1 and 2 feet from the ceiling.

The Transmitter emits an invisible infrared light beam that is reflected via a prism mounted directly opposite and with a clear line of sight. The reflected infrared light is detected by the Receiver and analysed.

The Detector has maximum lateral detection of 30 feet either side of the beam.

## 2. System Operation.

Smoke in the beam path will reduce the received infrared light proportionally to the density of the smoke. The Detector analyses this attenuation or obscuration of light and acts accordingly.

### 2.1. Alarm Threshold.

Alarm thresholds of 25%, 35%, and 50% can be selected to suit the environment, where 25% is the most sensitive. If the received infrared signal reduces to below the selected threshold and is present for approximately 10 seconds, the fire relay is activated.

### 2.2. Fire Alarm.

There are two modes to the operation of the fire relay. Auto reset mode will reset the fire relay 5 seconds after the received infrared signal has recovered to a level above the Alarm threshold. Latching mode holds the fire relay active indefinitely after an Alarm condition has occurred.

To clear the latched mode power must be removed from the Detector for a minimum of **5 seconds**.

### 2.3. Trouble Alarm.

If the infrared beam is obscured rapidly to a level of 90% or greater for approximately 10 seconds the Trouble relay is activated. This condition can be entered in a number of ways, for example, an object being placed in the beam path, transmitter failure, loss of the prism, or sudden misalignment of the Detector.

The Trouble relay will reset within 2 seconds of the condition being rectified.

### 2.4. Automatic Gain Control.

The Detector monitors long term degradation of signal strength caused by component ageing or build up of dirt on optical surfaces. This operates by comparing the received infrared signal against a standard every 15 minutes; differences of less than 0.7dB/Hour are corrected automatically. When the detector is showing AGC fault, the detector will still operate correctly indicating Alarm and Trouble as normal.

### 2.5. Low Level Controller Test (Optional Extra).

The detector has a 2-pin port to allow the use of an optional extra Low Level Control unit (see fig.4). The Low Level Controller will simulate an Alarm situation and cause the detector to go into an 'Alarm' condition.

### 3. Detector Positioning.

An infrared signal is projected out of the transmitter optics (see Fig 3) to the reflector placed at the opposite end of the detection zone. The signal is reflected back to the receiver where it is analysed for fire and Trouble.

It is important that the Fireray 50/100RU Detector is positioned correctly to minimise the detection time. Experiments have shown that smoke from a fire does not rise directly upwards, but fans out or mushrooms due to air currents and heat layering effects. A fire condition occurs when the infrared beam is obscured by a preset limit. The time to signal a fire condition depends on the location of the Detector within the premises, the volume of smoke produced, construction of the roof, and ventilation arrangements.

The maximum lateral distance either side of the beam is found to be typically 30 feet for satisfactory detection under flat ceilings, providing a total area coverage of 19,800 square feet (60 feet X 330 feet).

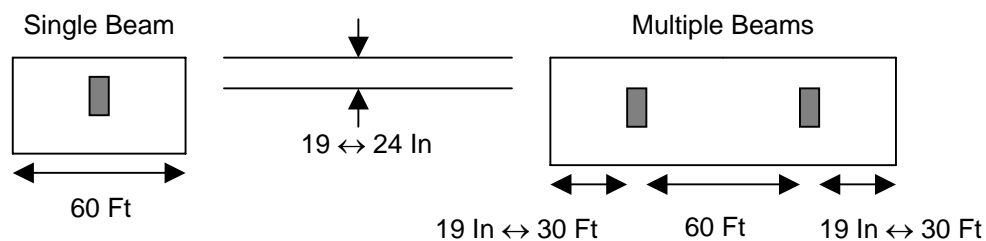

Smoke layering may be overcome by mounting the beam Detector at different heights, which will project the infra-red beam below the heat layer and into the smoke layer. Multiple beams at different heights may therefore be required.

Detection time will be longer in a building with a peaked roof if a fire occurs at the fringes of the protected area. If in doubt, prove operation by smoke tests.

The ideal location and spacing of the Detector is critical in a properly installed and operating fire alarm system. It is recommended that the detectors be located and spaced in accordance with the National Fire Protection Association (NFPA) Standard 72 "The National Fire Code". No liability will be accepted for applications not conforming to NFPA regulations.

The recommended installation height is approximately 19 to 24 inches below the ceiling. However, in all installations the National Fire Standards for that country/state must be consulted.

Because of the reflecting properties of the beam, all objects must be kept a minimum of 19 inches away from the centre of the beam path down the entire beam length. If highly reflective surfaces are close to the beam, then greater clearances should be applied.

## 4. Installation.

### 4.1. Pre-Installation At Ground Level.

Confirm that all parts have been supplied as listed in the parts list. See page 9.

Select the required Alarm threshold using switches 3 and 4 (See fig. 4. for switch configuration settings). The factory default setting is 35% this should be adequate for most environments, if the Detector is to be installed into an exceptionally dirty environment change the threshold to 50%.

Do not use the 25% Alarm threshold setting for the 100RU, as this does not conform to UL268.

Switch 1 selects latching or auto reset for the Alarm relay. The factory default setting is auto reset; change this option if required. See fig. 4.

The Detector Head Assembly is now ready for installation. If switches 1 to 4 require resetting after installation, a power down reset is required (entering into Alignment Mode can also be used as a reset).

**Do not install in locations where nominal ambient temperatures exceed 100°F.**

### 4.2. Detector Head Assembly Installation.

Remove the outer cover before installation; this is only to prevent the cover becoming dislodged during handling.

► **Do not mount on plasterboard or cladded walls as these surfaces do, and will move.** ◀

Determine the position of the Head Assembly, which must be mounted on a solid structure. Ensure that there is a clear line of sight to the proposed position of the prism.

Using the template provided mark and install all 4 fixing points to the structure. The rear mounting plate of the Detector Head Assembly is provided with 4 keyhole slotted apertures to allow for easy installation onto the 4 fixing points.

Replace the outer cover.

Terminate the field wiring. See section 8.

### 4.3. Prism Installation.

Due to the principle of the detector i.e. reflective, the prism must **NOT** be mounted on glass or a polished reflective surface.

Mount the Prism on a solid structure between 15 to 160 feet (Fireray 50RU), and 160 to 330 feet (Fireray 100RU) directly opposite the Detector.

50RU =  
1 Prism



100RU =  
4 Prisms

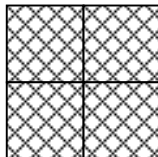

Ensure that there is a clear line of sight to the Detector, taking care that no moving objects i.e. doors, mechanical lifting equipment etc. Which will interfere with the light path between the Detector and Prism.

*Note: On ranges of  $\geq 15$  feet and  $\leq 160$  feet use a 50RU.  
On ranges of  $\geq 160$  feet and  $\leq 330$  feet use a 100RU.*

## 5. Prism Targeting Mode.

Apply power to the Detector. There is a 5 seconds pre-charge delay after power is applied to allow the internal circuits to stabilise correctly. After this period the RED indicator will flash once to indicate that the model is a 50RU or will flash twice to indicate a 100RU.

### **Do not remove the detector from the wall during this action.**

Using the mode switch (See fig. 4) select Prism Targeting Mode (Switch will be in the up position).

Find the prism by adjusting the horizontal and vertical thumbwheels until the AMBER indicator is continuously ON. The AMBER indicator will be OFF when no signal is being received, then will flash at an incrementing rate to determine the target position. The faster the flash the nearer you are to the target (prism).

- **At this point it is essential to test that the prism and not another surface is reflecting the beam.**

This can easily be confirmed by covering the prism with a non-reflecting surface and confirm that the AMBER indicator is OFF.

## 6. Alignment Mode.

Mechanical alignment is provided by two adjustment thumb wheels on two sides of the Detector, positioned just behind the Detector Head cover. Adjustment is achievable in both axes.

### 6.1. Enabling Alignment Mode.

### **Do not remove the detector from the wall during this action.**

Using the mode switch (See fig. 4) select Alignment Mode (Move switch to the middle position).

### 6.2. Adjustment in Alignment Mode.

The Detector will automatically adjust its infrared beam power and receiver sensitivity to give an optimum receiver signal strength.

The alignment progress is indicated by the color and state of the indicator lamp on the front of the Detector.

- **CONTINUOUSLY AMBER**  
The Detector is not receiving a signal. **Go back to prism targeting mode.**
- **FLASHING RED**  
The Detector is receiving too much signal and is attempting to reduce the infrared power output to compensate. **Wait** at this point until the indicator lamp is **OFF**, this may take up to 20 seconds depending on the distance between Detector and Prism, the shorter the distance the longer the time.

- **FLASHING AMBER**

The Detector is receiving a weak signal and is attempting to increase the infrared power output.

- **OFF**

The Detector has optimised the infrared power and receiver gain for the current orientation of the Detector and Prism. **This does not mean that the Detector to Prism alignment is at its optimum**, i.e. if the power is too high, a misaligned Detector may be receiving a fringe reflection from another object.

- **FLICKERING RED/AMBER**

This state can occur sometimes. It means that the infrared power is stepping through the optimum setting.

**Continue to flow  
diagram for procedure.**

6.3. Alignment Process Flow Diagram.

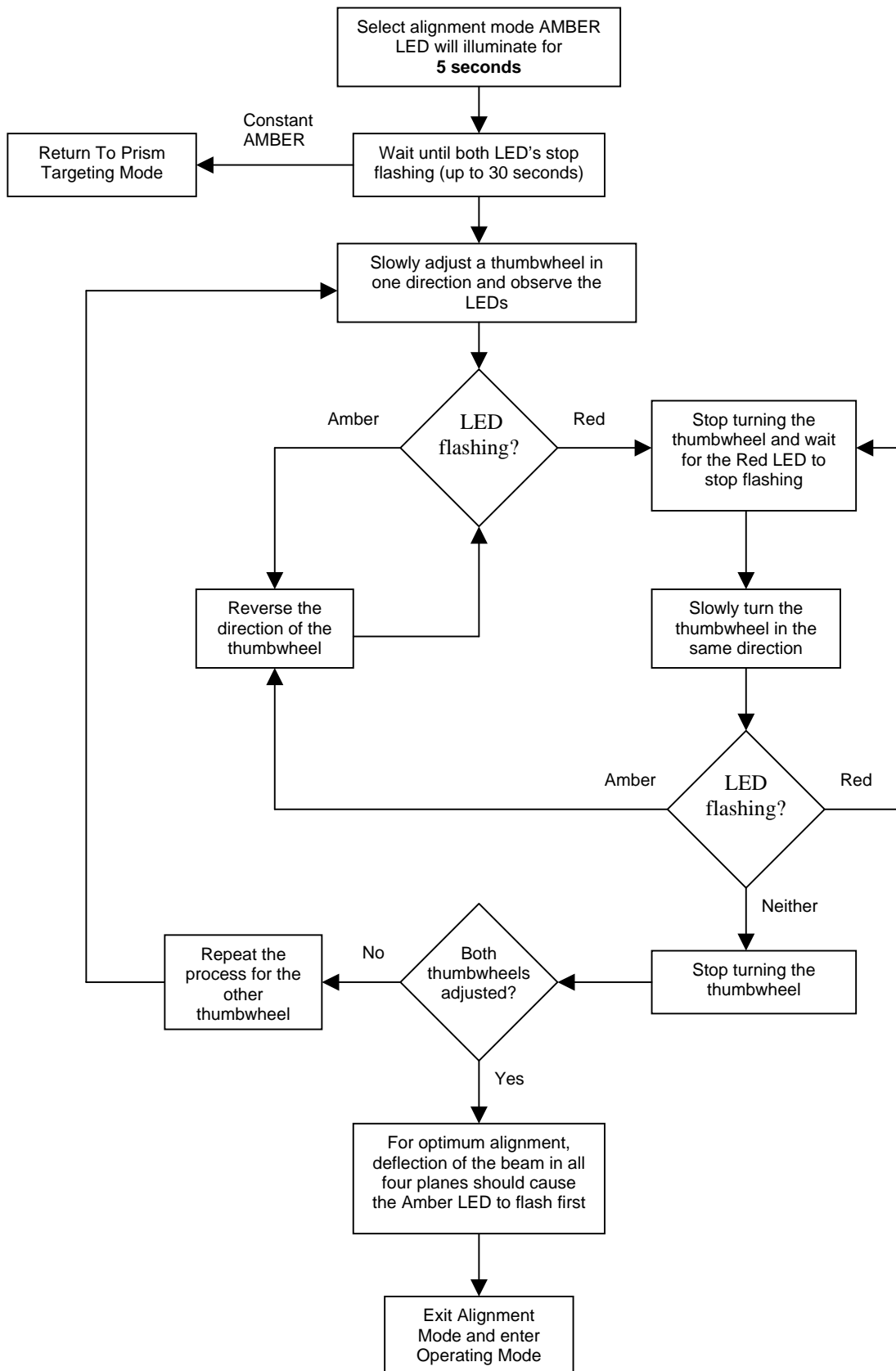

#### 6.4. Exiting Alignment Mode.

**Do not remove the detector from the wall during this action.**

Using the mode switch (See fig. 4) select Run Mode (Switch will be in the down position).

On exiting alignment mode the Detector will perform an internal calibration check, this can take up to 60 seconds. If this fails which would be due to bad alignment or either electrical or optical noise, the detector will indicate a Trouble condition. In this case the alignment procedure must be repeated. This could also occur during power up after loss of power.

If the internal calibration check completes satisfactory the detector will be in normal running mode.

### 7. System Testing.

After successful installation and alignment the System will require testing for both Alarm and Trouble conditions. This is to verify the functionality of the detector.

#### 7.1. Alarm (smoke) Test.

Taking note of the threshold selected during installation (default 35%).

Select obscuration mark on filter to correspond with the Detector Alarm threshold (see fig. 3).

Place the filter over the receiver optics (Top of Detector Head – opposite end to the status indication LED's) at the correct obscuration value determined by the threshold selected. I.e. if a threshold of 35% has been selected position the filter just past the 35% obscuration value on the filter (see fig 3.).

Take care not to cover the transmitter optics.

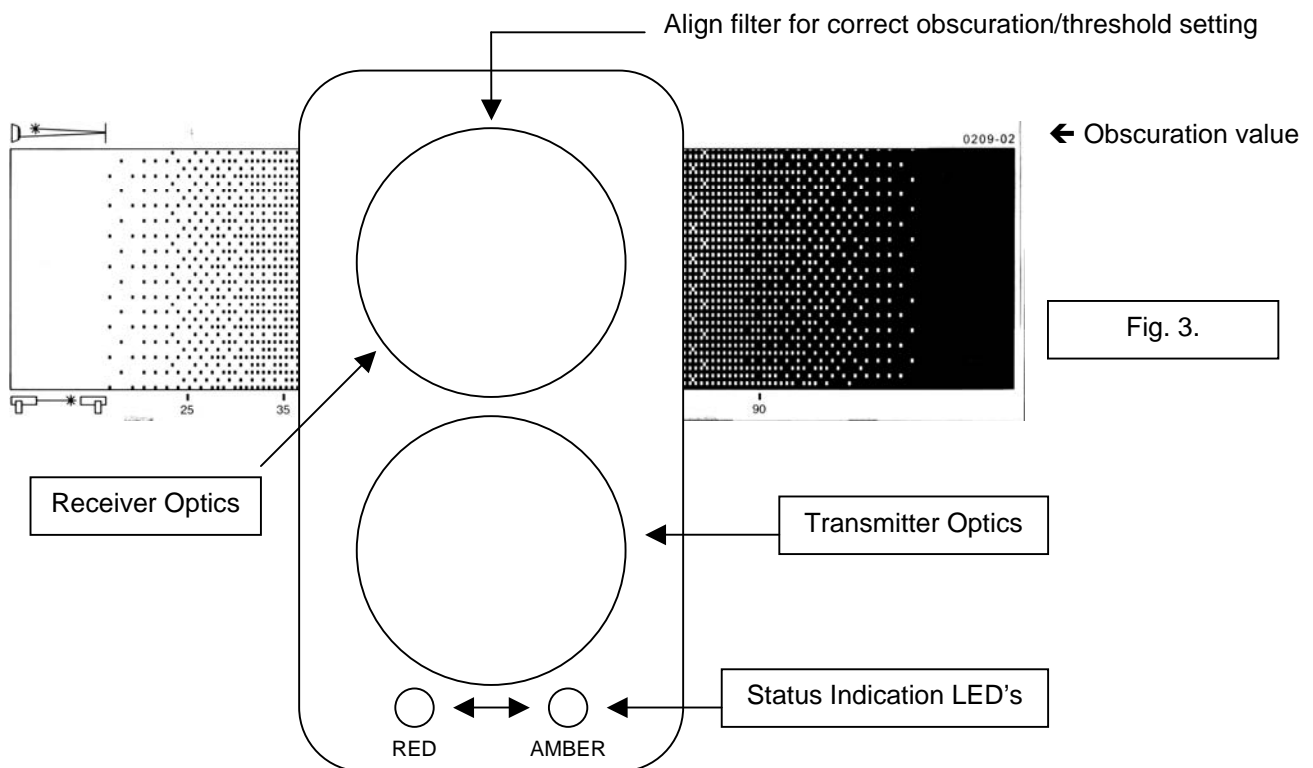

## 7.2. Trouble Test.

Cover the Prism totally with a non-reflective material and confirm that the Detector indicates a Trouble condition after approximately 10 seconds (the amber LED on the Detector will illuminate, and the Trouble relay opening will indicate this). The Trouble condition will automatically reset after a period not greater than 2 seconds when the obstruction is removed.

## 8. Connection and Configuration Settings.

### 8.1. Field Wiring.

The field-wiring interface is accessed through the back plate of the Detector Head (See Fig 4). The 2-pin connector is the port for the Low Level Controller. The 8-pin connector is the interface to the field wiring and is numbered left to right. Each unit is fitted with a 'flying' lead, with an 8-pin connector fitted (6 pins used), for easy field wiring. See table below:

Pin Number	Wire Color	Signal Description
1		n/a
2	BLUE	Fire relay common (COM) connection
3	YELLOW	Fire relay normally open (NO) connection
4	RED	Positive Supply (+10.2 to +30 Volts DC)
5	BLACK	Negative Supply (0V)
6	GREEN	Trouble relay normally closed (NC) connection
7	WHITE	Trouble relay common connection (COM) connection
8		n/a

### 8.2. DIP Switch Settings.

Access to the configuration settings is through the back plate of the Detector Head (See Fig 4). Default configuration settings are marked ←.

Function	1	2	3	4	
50% Threshold	X	X	OFF	OFF	
35% Threshold	X	X	OFF	ON	←
25% Threshold	X	X	ON	OFF	
<i>12% Threshold (Do Not Use – Future Requirement)</i>	X	X	ON	ON	
Latching Fire Relay	OFF	X	X	X	
Auto Reset Fire Relay (5 seconds)	ON	X	X	X	←
Fire Relay Enable On Compensation Limit	X	OFF	X	X	←
Fire Relay Disable On Compensation Limit	X	ON	X	X	

**9. Typical single zone wiring diagram.**

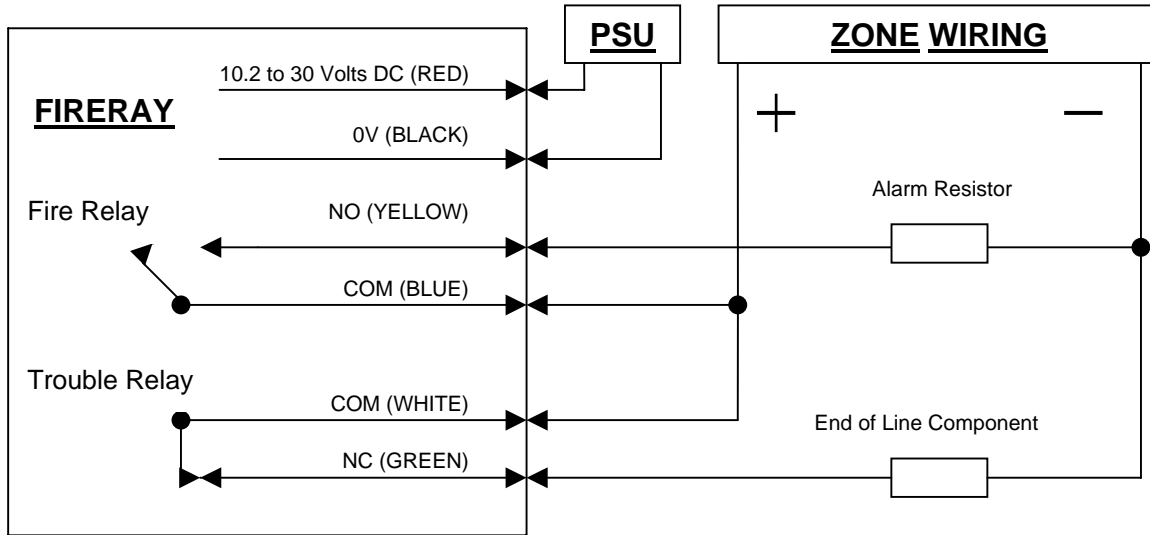

This diagram is an example for a single Fireray being the only device on a zone. The correct operation for Fire and Trouble should always be checked connected to a typical panel. Relays are shown in normal powered no fault condition. Contact fire panel manufacturer for values of 'Alarm Resistor' and 'End of Line Component'.

**10. Detector Interface Assembly Configuration Settings (not to scale).**

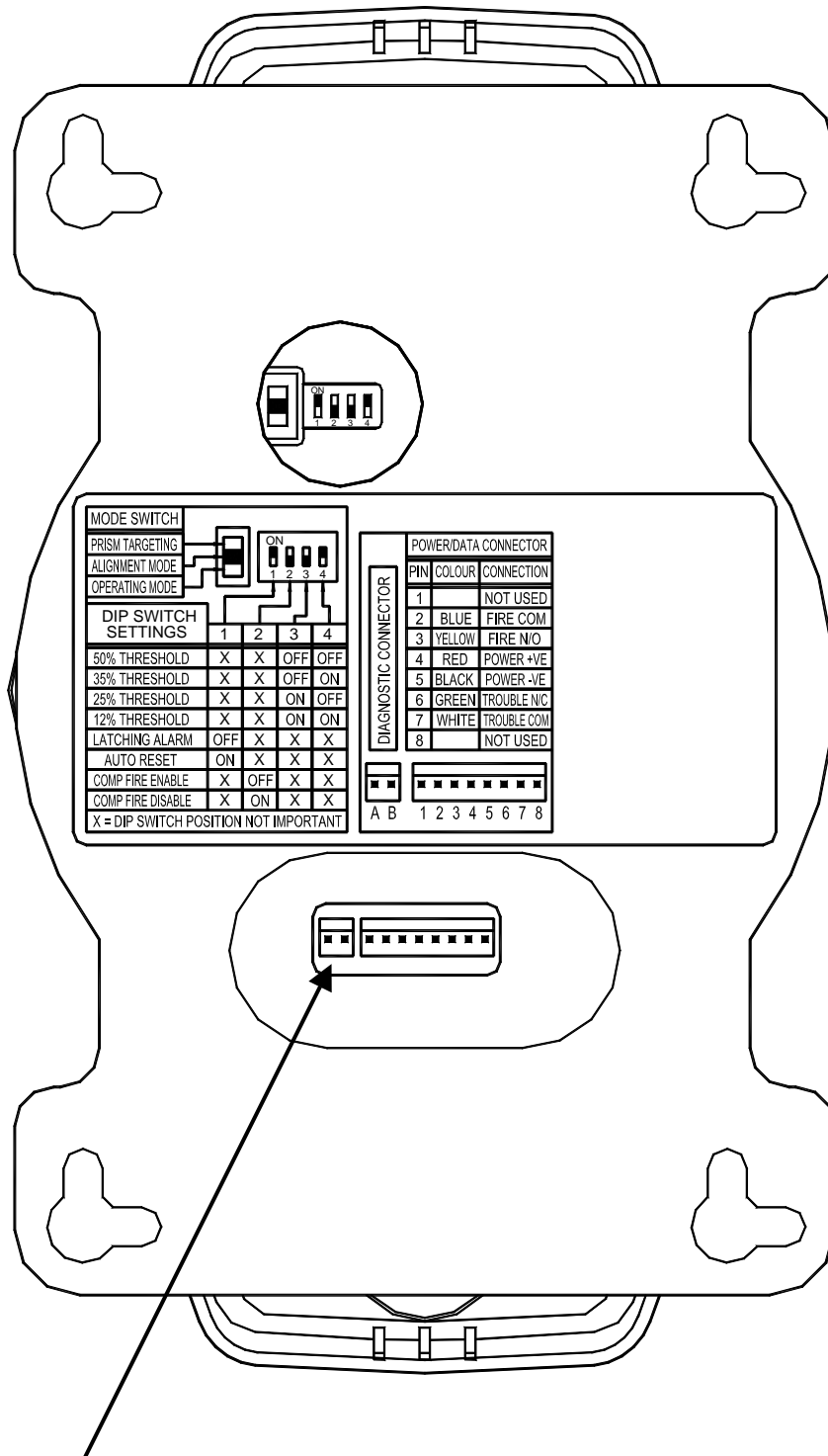

DIP SWITCH SETTINGS				
	1	2	3	4
50% THRESHOLD	X	X	OFF	OFF
35% THRESHOLD	X	X	OFF	ON
25% THRESHOLD	X	X	ON	OFF
12% THRESHOLD	X	X	ON	ON
LATCHING ALARM	OFF	X	X	X
AUTO RESET	ON	X	X	X
COMP FIRE ENABLE	X	OFF	X	X
COMP FIRE DISABLE	X	ON	X	X

X = DIP SWITCH POSITION NOT IMPORTANT

POWER/DATA CONNECTOR		
PIN	COLOUR	CONNECTION
1		NOT USED
2	BLUE	FIRE COM
3	YELLOW	FIRE N/O
4	RED	POWER +VE
5	BLACK	POWER -VE
6	GREEN	TROUBLE N/C
7	WHITE	TROUBLE COM
8		NOT USED

2-pin port for optional Low Level Controller

Fig. 4.

## 11. Technical Data.

- Operating Range Fireray 50RU 15 to 160 Feet
- Operating Range Fireray 100RU 160 to 330 Feet
- Lateral Coverage 30 Feet (either side of the beam)
- Supply Voltage 10.2 to 30 Volts DC
- Quiescent Current Less than 4mA
- Alarm/Trouble Current Less than 20mA
- Alarm Contacts Normally Open contacts rated 1 amps, 30 Volts DC, resistive
- Trouble Contacts Normally Closed contacts rated 1 amps, 30 Volts DC, resistive
- Relay Contacts (all) Maximum voltage 220 Volts DC, 30 watts, resistive
- Alarm and Trouble Signal Delay 10 seconds
- Power Down Reset Time >5 seconds
- Operating Temperature 32°F to 100°F
- Moisture RH (max) 93% (non condensing)
- Fire Alarm Thresholds 2.50dB (25%), 3.74dB (35%), 6.02dB (50%)
- Optical Wavelength 880nm
- Head Maximum Size Width 5.1 inches, Height 8.25 inches, Depth 4.7 inches
- Weight 24 ounces

## 12. Service / Application Notes.

- Red LED indicates FIRE.
- Continuous Amber LED indicates TROUBLE.
- Flashing Amber LED once every 2 seconds indicates that the contamination/compensation function has reached its limit.
- Alarm condition indicated by fire relay closing (relay contact is normally open).
- Trouble condition indicated by Trouble relay opening (relay contact is normally closed).
- Alarm may be latching or non-latching (default).
- Periodic cleaning with a lint free soft cloth is required.

## 13. Parts List.

- 1 off: Detector Head Assembly with cable interface
- 1 off: Prism for the 50RU or 4 off: Prisms for the 100RU
- 1 off: Test Filter

## 14. Optional Extra Parts List.

- Low Level Controller (Optional Extra Part Number 0400-01-XX, where XX is the latest version)

## 15. Technical Support.

- Toll free hotline within USA 1-866-FIRERAY (347-3729)
- E-mail: [sales@ffeuk.com](mailto:sales@ffeuk.com)
- Website: [www.ffeuk.com](http://www.ffeuk.com)